

BUTT WELD IN-LINE FLANGES (Pg 1/2)

For Schedule XXS Pipe ⑥

SAE J518 61 SERIES / ISO6162-1 PATTERN

FLANGE SIZE	PIPE SIZE	PART NUMBER	A	B	C	D	E	F	Gmm		H	K	MOUNTING KIT®			WT
									Jmm				PART NO.	SCREW SIZE	O-RING	
1/2	1/2	1121-08-08M8	1.50	2.12	1.25	1.500	.688	.25	8.5	.38	.88	MKM 512	M8 x 35	210	.8	
		M8x1.25														
3/4	1/2	1121-12-08M10	1.75	2.62	1.25	1.875	.875	.25	10.5	.38	.88	MKM 1525	M10 x 35	214	1.1	
		M10x1.5														
3/4	3/4	1121-12-12M10	1.75	2.62	1.25	1.875	.875	.44	10.5	.38	1.12	MKM 1525	M10 x 35	214	1.1	
		M10x1.5														
1	3/4	1121-16-12M10	2.00	2.82	1.38	2.062	1.031	.44	10.5	.50	1.12	MKM 1542	M10 x 35	219	1.4	
		M10x1.5														
1	1	1121-16-16M10	2.00	2.82	1.38	2.062	1.031	.60	10.5	.50	1.38	MKM 1542	M10 x 35	219	1.4	
		M10x1.5														
1 1/4	1	1121-20-16M10†	2.50	3.19	1.38	2.312	1.188	.60	10.5	.50	1.38	MKM 4520	M10 x 35	222	2.0	
		M10x1.5														
1 1/4	1 1/4	1121-20-20M10†	2.50	3.19	1.38	2.312	1.188	.89	10.5	.50	1.75	MKM 4520	M10 x 35	222	1.9	
		M10x1.5														
1 1/4	1 1/2	-----	2.50	3.19	1.50	2.312	1.188	1.10	---	.50	2.00	-----	-----	---	2.1	
		M10x1.5														
1 1/2	1 1/4	1121-24-20M12‡	2.75	3.75	1.50	2.750	1.406	.89	13.0	.50	1.75	MKM 4551	M12 x 40	225	2.8	
		M12x1.75														
1 1/2	1 1/2	1121-24-24M12‡	2.75	3.75	1.50	2.750	1.406	1.10	13.0	.50	2.00	MKM 4551	M12 x 40	225	2.7	
		M12x1.75														
1 1/2	2	-----	3.50	3.75	2.50	2.750	1.406	1.50	---	.75	2.50	-----	-----	---	5.9	
		M12x1.75														

MATERIAL:
Low Carbon Steel

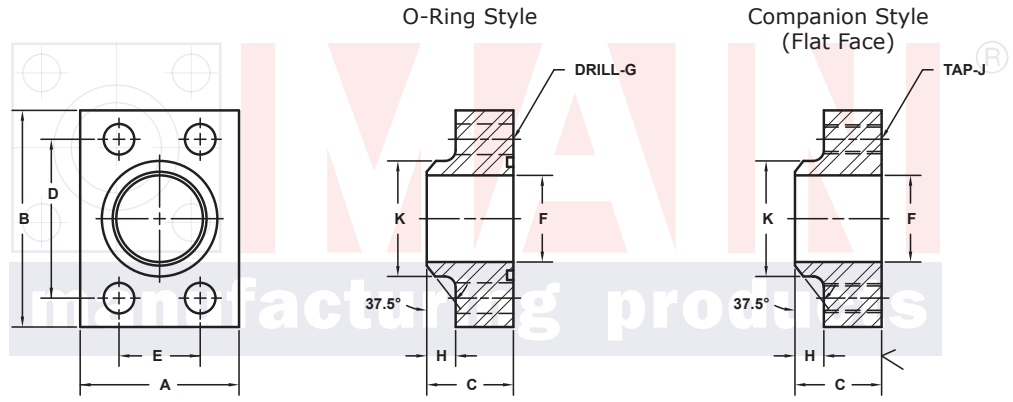

3181 TRI-PARK DR. GRAND BLANC, MI 48439 800-521-7918 810-953-1380 FAX 810-953-1385 INFO@MAINMFG.COM

SAE J518 62 SERIES / ISO6162-2 PATTERN

FLANGE SIZE	PIPE SIZE	PART NUMBER	A	B	C	D	E	F	Gmm		H	K	MOUNTING KIT®			WT
									Jmm				PART NO.	SCREW SIZE	O-RING	
1/2	1/2	1123-08-08M8	1.75	2.22	1.25	1.594	.718	.25	8.5	.38	.88	MKM 512	M8 x 35	210	.9	
		M8x1.25														
3/4	1/2	1123-12-08M10	2.00	2.81	1.25	2.000	.937	.25	10.5	.38	.88	MKM 1525	M10 x 35	214	1.3	
		M10x1.5														
3/4	3/4	1123-12-12M10	2.00	2.81	1.25	2.000	.937	.44	10.5	.38	1.12	MKM 1525	M10 x 35	214	1.3	
		M10x1.5														
1	3/4	1123-16-12M12	2.25	3.19	1.50	2.250	1.093	.44	12.5	.50	1.12	MKM 4569	M12 x 40	219	2.0	
		M12x1.75														
1	1	1123-16-16M12	2.25	3.19	1.50	2.250	1.093	.60	12.5	.50	1.38	MKM 4569	M12 x 40	219	2.0	
		M12x1.75														
1 1/4	1	1123-20-16M12‡	2.75	3.75	1.50	2.625	1.250	.60	13.0	.50	1.38	MKM 1527	M12 x 40	222	2.8	
		M12x1.75														
1 1/4	1 1/4	1123-20-20M12‡	2.75	3.75	1.50	2.625	1.250	.89	13.0	.50	1.75	MKM 1527	M12 x 40	222	2.8	
		M12x1.75														
1 1/4	1 1/2	-----	3.00	3.75	1.75	2.625	1.250	1.10	---	.75	2.00	-----	-----	---	3.1	
		M12x1.75														

① Order Separately

⑥ Other Pipe and Tube Sizes are Available

NOTE: DIMENSIONS ARE IN INCHES UNLESS OTHERWISE NOTED. † Also Available for M12 Bolts ‡ Also Available for M14 Bolts

© Copyright MAIN Mfg. 2017

BUTT WELD IN-LINE FLANGES (Pg 2/2)

For Schedule XXS Pipe ⑥

SAE J518 61 SERIES / ISO6162-1 PATTERN

FLANGE SIZE	PIPE SIZE	PART NUMBER	A	B	C	D	E	F	Gmm		H	K	MOUNTING KIT①			WT
									Jmm				PART NO.	SCREW SIZE	O-RING	
2	1¼	1121-32-20M12+	3.25	4.00	1.50	3.062	1.688	.89	13.0	.50	1.75	M12 x 45	M12 x 45	228	3.5	
		M12x1.75							-----							---
2	1½	1121-32-24M12+	3.25	4.00	1.50	3.062	1.688	1.10	13.0	.50	2.00	M12 x 45	M12 x 45	228	3.5	
		M12x1.75							-----							---
2	2	1121-32-32M12+	3.25	4.00	1.75	3.062	1.688	1.50	13.0	.75	2.50	M12 x 45	M12 x 45	228	3.6	
		M12x1.75							-----							---
2½ ^②	2	1121-40-32M12+	4.00	4.50	2.00	3.500	2.000	1.50	13.0	.75	2.50	M12 x 50	M12 x 50	232	6.1	
		M12x1.75							-----							---
2½ ^②	2½	1121-40-40M12+	4.00	4.50	2.00	3.500	2.000	1.77	13.0	.75	3.00	M12 x 50	M12 x 50	232	6.0	
		M12x1.75							-----							---
3 ^③	2½	1121-48-40M16	4.50	5.31	2.25	4.188	2.438	1.77	17.0	.75	3.00	M16 x 60	M16 x 60	237	9.5	
		M16x2							-----							---
3 ^③	3	1121-48-48M16	4.50	5.31	2.25	4.188	2.438	2.30	17.0	.75	3.50	M16 x 60	M16 x 60	237	8.8	
		M16x2							-----							---
3½ ^④	3	1121-56-48M16	5.00	6.00	1.75	4.750	2.750	2.30	17.0	.75	3.50	M16 x 50	M16 x 50	241	7.9	
		M16x2							-----							---
3½ ^④	3½	1121-56-56M16	5.00	6.00	1.75	4.750	2.750	2.73	17.0	.75	4.00	M16 x 50	M16 x 50	241	7.6	
		M16x2							-----							---
4 ^④	3	1121-64-48M16	5.50	6.38	1.75	5.125	3.062	2.30	17.0	.75	3.50	M16 x 50	M16 x 50	245	9.3	
		M16x2							-----							---
4 ^④	4	1121-64-64M16	5.50	6.38	1.75	5.125	3.062	3.15	17.0	.75	4.50	M16 x 50	M16 x 50	245	8.7	
		M16x2							-----							---

MATERIAL:
Low Carbon Steel

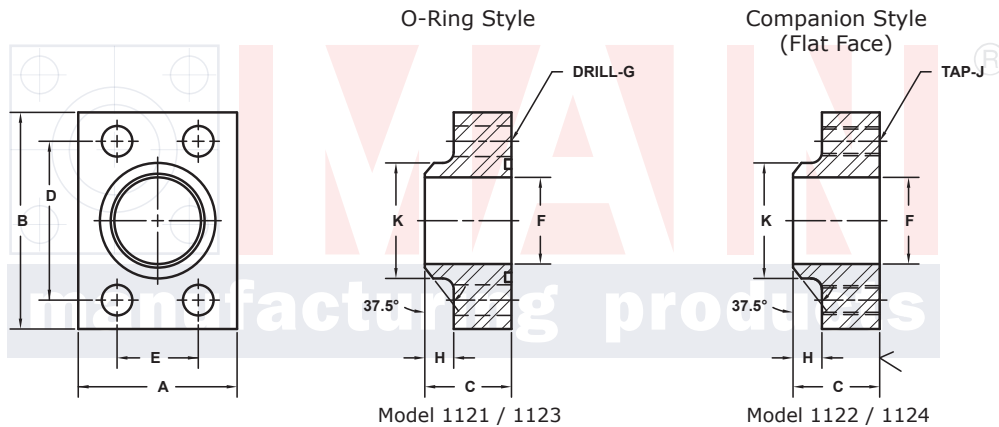

Model 1121 / 1123

Model 1122 / 1124

3181 TRI-PARK DR. GRAND BLANC, MI 48439 800-521-7918 810-953-1380 FAX 810-953-1385 INFO@MAINMFG.COM

SAE J518 62 SERIES / ISO6162-2 PATTERN

FLANGE SIZE	PIPE SIZE	PART NUMBER	A	B	C	D	E	F	Gmm		H	K	MOUNTING KIT①			WT
									Jmm				PART NO.	SCREW SIZE	O-RING	
1½	1¼	1123-24-20M16	3.25	4.50	1.50	3.125	1.437	.89	17.0	.50	1.75	M16 x 45	M16 x 45	225	3.9	
		M16x2							-----							---
1½	1½	1123-24-24M16	3.25	4.50	1.50	3.125	1.437	1.10	17.0	.50	2.00	M16 x 45	M16 x 45	225	3.9	
		M16x2							-----							---
1½	2	-----	4.00	4.50	2.00	3.125	1.437	1.50	-----	.75	2.50	-----	-----	---	6.0	
		M16x2							-----							---
2	1½	1123-32-24M20	4.00	5.25	1.75	3.812	1.750	1.10	21.0	.50	2.00	M20 x 60	M20 x 60	228	6.9	
		M20x2.5							-----							---
2	2	1123-32-32M20	4.00	5.25	2.00	3.812	1.750	1.50	21.0	.75	2.50	M20 x 60	M20 x 60	228	6.9	
		M20x2.5							-----							---
2½	2	1123-40-32M24	5.00	6.88	2.50	4.875	2.312	1.50	25.5	.75	2.50	M24 x 70	M24 x 70	232	15.8	
		M24x3							-----							---
2½	2½	1123-40-40M24	5.00	6.88	2.50	4.875	2.312	1.77	25.5	.75	3.00	M24 x 70	M24 x 70	232	15.7	
		M24x3							-----							---
3	3	1123-48-48M30	6.00	8.50	3.00	6.000	2.812	2.30	32.0	.88	3.50	M30 x 100	M30 x 100	237	27.4	
		M30x3.5							-----							---

① Order Separately ② 2500 PSI Max ③ 2000 PSI Max ④ 500 PSI Max

⑥ Other Pipe and Tube Sizes are Available

NOTE: DIMENSIONS ARE IN INCHES UNLESS OTHERWISE NOTED. + Also Available for M12 Bolts † Also Available for M14 Bolts

© Copyright MAIN Mfg. 2017