

# BSPP THREADED IN-LINE FLANGES

## SAE J518 61 SERIES / ISO6162-1 PATTERN

FLANGE SIZE	PORT SIZE	PART NUMBER	A	B	C	D	E	F	Gmm	K	MOUNTING KIT®			WT
									Jmm		PART NO.	SCREW SIZE	O-RING	
1/2	-8	1351-08-08M8	1.50	2.12	1.25	1.500	.688	.50	8.5	1/2-14	MKM 501	M8 x 30	210	.8
		M8x1.25							-----		-----	---		
3/4	-8	1351-12-08M10	1.75	2.62	1.50	1.875	.875	.74	10.5	1/2-14	MKM 1525	M10 x 35	214	1.4
		M10x1.5							-----		-----	---		
3/4	-12	1351-12-12M10	1.75	2.62	1.50	1.875	.875	.75	10.5	3/4-14	MKM 1525	M10 x 35	214	1.3
		M10x1.5							-----		-----	---		
1	-12	1351-16-12M10	2.00	2.82	1.50	2.062	1.031	.94	10.5	3/4-14	MKM 1542	M10 x 35	219	1.7
		M10x1.5							-----		-----	---		
1	-16	1351-16-16M10	2.00	2.82	1.50	2.062	1.031	1.00	10.5	1-11	MKM 1542	M10 x 35	219	1.6
		M10x1.5							-----		-----	---		
1 1/4	-20	1351-20-20M10†	2.50	3.19	1.50	2.312	1.188	1.25	10.5	1 1/4-11	MKM 4520	M10 x 35	222	2.1
		M10x1.5							-----		-----	---		
1 1/2	-20	1351-24-20M12‡	2.75	3.75	1.75	2.750	1.406	1.50	13.0	1 1/4-11	MKM 2599	M12 x 45	225	3.4
		M12x1.75							-----		-----	---		
1 1/2	-24	1351-24-24M12‡	2.75	3.75	1.75	2.750	1.406	1.50	13.0	1 1/2-11	MKM 2599	M12 x 45	225	3.2
		M12x1.75							-----		-----	---		
2	-24	1351-32-24M12‡	3.25	4.00	1.75	3.062	1.688	1.75	13.0	1 1/2-11	MKM 4513	M12 x 45	228	4.5
		M12x1.75							-----		-----	---		
2	-32	1351-32-32M12‡	3.25	4.00	2.00	3.062	1.688	1.94	13.0	2-11	MKM 4513	M12 x 45	228	3.8
		M12x1.75							-----		-----	---		
2 1/2	-32	1351-40-32M12‡	4.00	4.50	1.75	3.500	2.000	2.12	13.0	2-11	MKM 3562	M12 x 45	232	6.2
		M12x1.75							-----		-----	---		

MATERIAL:  
Low Carbon Steel<sup>®</sup>

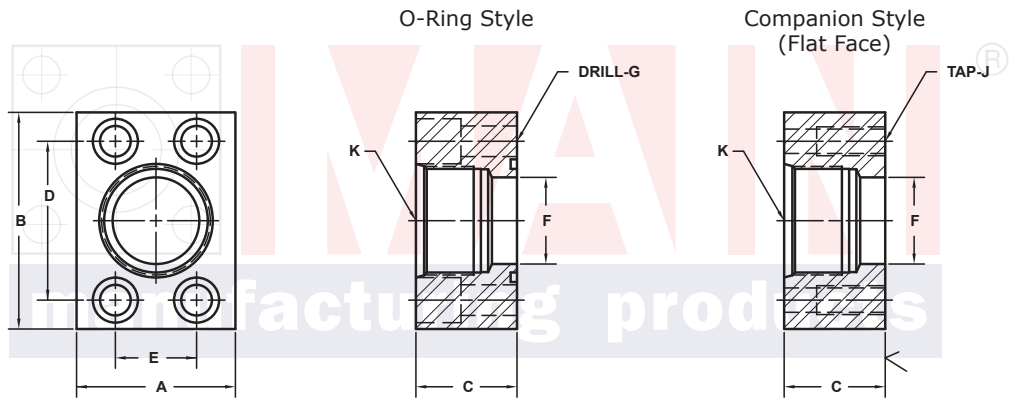
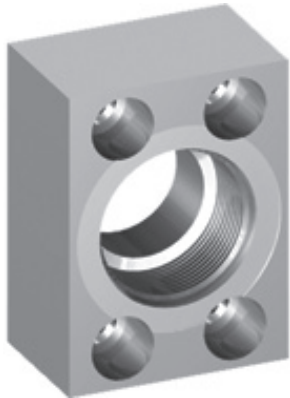

3181 TRI-PARK DR. GRAND BLANC, MI 48439 800-521-7918 810-953-1380 FAX 810-953-1385 INFO@MAINMFG.COM

## SAE J518 62 SERIES / ISO6162-2 PATTERN

FLANGE SIZE	PORT SIZE	PART NUMBER	A	B	C	D	E	F	Gmm	K	MOUNTING KIT®			WT
									Jmm		PART NO.	SCREW SIZE	O-RING	
1/2	-8	1353-08-08M8	1.75	2.22	1.25	1.594	.718	.50	8.5	1/2-14	MKM 501	M8 x 30	210	1.0
		M8x1.25							-----		-----	---		
3/4	-8	1353-12-08M10	2.00	2.81	1.50	2.000	.937	.74	10.5	1/2-14	MKM 1525	M10 x 35	214	1.9
		M10x1.5							-----		-----	---		
3/4	-12	1353-12-12M10	2.00	2.81	1.50	2.000	.937	.75	10.5	3/4-14	MKM 1525	M10 x 35	214	1.7
		M10x1.5							-----		-----	---		
1	-12	1353-16-12M12	2.25	3.19	1.50	2.250	1.093	.94	12.5	3/4-14	MKM 1529	M12 x 40	219	2.3
		M12x1.75							-----		-----	---		
1	-16	1353-16-16M12	2.25	3.19	1.50	2.250	1.093	1.00	12.5	1-11	MKM 1529	M12 x 40	219	2.1
		M12x1.75							-----		-----	---		
1 1/4	-20	1353-20-20M12‡	3.00	3.75	1.50	2.625	1.250	1.25	13.0	1 1/4-11	MKM 567	M12 x 35	222	3.4
		M12x1.75							-----		-----	---		
1 1/2	-24	1353-24-24M16	3.25	4.50	1.75	3.125	1.437	1.50	17.0	1 1/2-11	MKM 1544	M16 x 45	225	4.9
		M16x2							-----		-----	---		
2	-32	1353-32-32M20	4.00	5.25	2.00	3.812	1.750	1.94	21.0	2-11	MKM 563	M20 x 45	228	6.7
		M20x2.5							-----		-----	---		

① Order Separately

② 2500 PSI Max

⑤ May Contain Lead

**NOTE:** The Pressure Rating of the Assembly Should NOT Exceed the Lower of the Flange Pad or the Fitting. Check the Fitting Manufacturer for Details.

NOTE: DIMENSIONS ARE IN INCHES UNLESS OTHERWISE NOTED. † Also Available for M12 Bolts ‡ Also Available for M14 Bolts

© Copyright MAIN Mfg. 2017