

NPTF THREADED IN-LINE FLANGES (Pg 1/2)

SAE BOLT PATTERN										61 SERIES				
FLANGE SIZE	PIPE SIZE	PART NUMBER	A	B	C	D	E	F	G J	K NPTF	MOUNTING KIT®			WT
											PART NO.	SCREW SIZE	O-RING	
1/2	1/2	1149-08-08	1.50	2.12	1.25	1.500	.688	.50	.34	1/2	MK 519	5/16-18 x 1 3/4	210	.8
		1150-08-08							5/16-18					
3/4	1/2	1149-12-08	1.75	2.62	1.25	1.875	.875	.70	.41	1/2	MK 520	3/8-16 x 2	214	1.3
		1150-12-08							3/8-16					
3/4	3/4	1149-12-12	1.75	2.62	1.25	1.875	.875	.75	.41	3/4	MK 520	3/8-16 x 2	214	1.2
		1150-12-12							3/8-16					
1	3/4	1149-16-12	2.00	2.82	1.50	2.062	1.031	.92	.41	3/4	MK 521	3/8-16 x 2 1/4	219	1.9
		1150-16-12							3/8-16					
1	1	1149-16-16	2.00	2.82	1.50	2.062	1.031	1.00	.41	1	MK 521	3/8-16 x 2 1/4	219	1.7
		1150-16-16							3/8-16					
1 1/4	1	1149-20-16	2.50	3.19	1.50	2.312	1.188	1.16	.47	1	MK 522	7/16-14 x 2 1/4	222	2.6
		1150-20-16							7/16-14					
1 1/4	1 1/4	1149-20-20	2.50	3.19	1.50	2.312	1.188	1.25	.47	1 1/4	MK 522	7/16-14 x 2 1/4	222	2.3
		1150-20-20							7/16-14					
1 1/4	1 1/2	-----	3.00	3.19	3.00	2.312	1.188	1.25	----	1 1/2	-----	-----	----	6.4
		1150-20-24							7/16-14					
1 1/2	1 1/4	1149-24-20	2.75	3.75	1.75	2.750	1.406	1.50	.53	1 1/4	MK 523	1/2-13 x 2 1/2	225	3.8
		1150-24-20							1/2-13					
1 1/2	1 1/2	1149-24-24	2.75	3.75	1.75	2.750	1.406	1.50	.53	1 1/2	MK 523	1/2-13 x 2 1/2	225	3.6
		1150-24-24							1/2-13					
1 1/2	2	-----	3.50	3.75	3.50	2.750	1.406	1.50	----	2	-----	-----	----	10.1
		1150-24-32							1/2-13					

MATERIAL:
Low Carbon Steel[®]

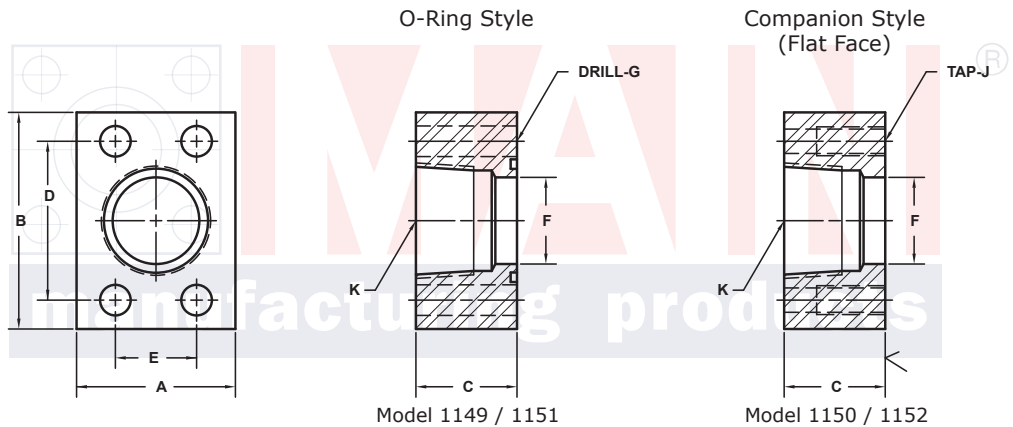
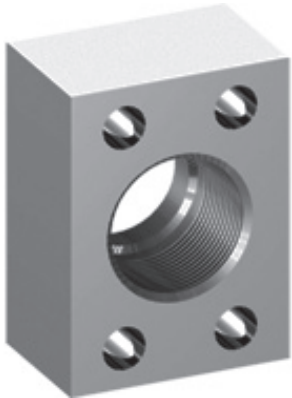

3181 TRI-PARK DR. GRAND BLANC, MI 48439 800-521-7918 810-953-1380 FAX 810-953-1385 INFO@MAINMFG.COM

SAE BOLT PATTERN										62 SERIES				
FLANGE SIZE	PIPE SIZE	PART NUMBER	A	B	C	D	E	F	G J	K NPTF	MOUNTING KIT®			WT
											PART NO.	SCREW SIZE	O-RING	
1/2	1/2	1151-08-08	1.75	2.22	1.25	1.594	.718	.50	.34	1/2	MK 519	5/16-18 x 1 3/4	210	1.1
		1152-08-08							5/16-18					
3/4	1/2	1151-12-08	2.00	2.81	1.25	2.000	.937	.70	.41	1/2	MK 520	3/8-16 x 2	214	1.6
		1152-12-08							3/8-16					
3/4	3/4	1151-12-12	2.00	2.81	1.25	2.000	.937	.75	.41	3/4	MK 520	3/8-16 x 2	214	1.5
		1152-12-12							3/8-16					
1	3/4	1151-16-12	2.25	3.19	1.50	2.250	1.093	.92	.47	3/4	MK 525	7/16-14 x 2 1/4	219	2.4
		1152-16-12							7/16-14					
1	1	1151-16-16	2.25	3.19	1.50	2.250	1.093	1.00	.47	1	MK 525	7/16-14 x 2 1/4	219	2.3
		1152-16-16							7/16-14					
1 1/4	1	1151-20-16	3.00	3.75	1.50	2.625	1.250	1.16	.53	1	MK 526	1/2-13 x 2 1/4	222	3.9
		1152-20-16							1/2-13					
1 1/4	1 1/4	1151-20-20	3.00	3.75	1.50	2.625	1.250	1.25	.53	1 1/4	MK 526	1/2-13 x 2 1/4	222	3.7
		1152-20-20							1/2-13					
1 1/4	1 1/2	-----	3.00	3.75	3.00	2.625	1.250	1.25	----	1 1/2	-----	-----	----	7.9
		1152-20-24							1/2-13					

① Order Separately

® May Contain Lead

NPTF THREADED IN-LINE FLANGES (Pg 2/2)

SAE BOLT PATTERN										61 SERIES				
FLANGE SIZE	PIPE SIZE	PART NUMBER	A	B	C	D	E	F	G J	K NPTF	MOUNTING KIT®			WT
											PART NO.	SCREW SIZE	O-RING	
2	1 1/4	1149-32-20	3.25	4.00	1.75	3.062	1.688	1.50	.53	1 1/4	MK 524	1/2-13 x 2 1/2	228	5.2
		1150-32-20	-----	-----	-----	-----	-----	-----	1/2-13		-----			
2	1 1/2	1149-32-24	3.25	4.00	1.75	3.062	1.688	1.74	.53	1 1/2	MK 524	1/2-13 x 2 1/2	228	4.9
		1150-32-24	-----	-----	-----	-----	-----	-----	1/2-13		-----			
2	2	1149-32-32	3.25	4.00	1.75	3.062	1.688	1.94	.53	2	MK 524	1/2-13 x 2 1/2	228	4.2
		1150-32-32	-----	-----	-----	-----	-----	-----	1/2-13		-----			
2 1/2 ^②	1 1/2	1149-40-24	4.00	4.50	2.00	3.500	2.000	1.74	.53	1 1/2	MK 1515	1/2-13 x 2 3/4	232	8.5
		1150-40-24	-----	-----	-----	-----	-----	-----	1/2-13		-----			
2 1/2 ^②	2	1149-40-32	4.00	4.50	2.00	3.500	2.000	2.12	.53	2	MK 1515	1/2-13 x 2 3/4	232	7.5
		1150-40-32	-----	-----	-----	-----	-----	-----	1/2-13		-----			
2 1/2 ^②	2 1/2	1149-40-40	4.00	4.50	2.00	3.500	2.000	2.44	.53	2 1/2	MK 1515	1/2-13 x 2 3/4	232	6.5
		1150-40-40	-----	-----	-----	-----	-----	-----	1/2-13		-----			
3 ^③	2	1149-48-32	4.50	5.50	2.25	4.188	2.438	2.12	.66	2	MK 1516	5/8-11 x 3 1/4	237	12.5
		1150-48-32	-----	-----	-----	-----	-----	-----	5/8-11		-----			
3 ^③	2 1/2	1149-48-40	4.50	5.50	2.25	4.188	2.438	2.62	.66	2 1/2	MK 1516	5/8-11 x 3 1/4	237	11.4
		1150-48-40	-----	-----	-----	-----	-----	-----	5/8-11		-----			
3 ^③	3	1149-48-48	4.50	5.50	2.25	4.188	2.438	2.94	.66	3	MK 1516	5/8-11 x 3 1/4	237	9.8
		1150-48-48	-----	-----	-----	-----	-----	-----	5/8-11		-----			
3 1/2 ^④	3 1/2	1149-56-56	5.00	6.00	2.25	4.750	2.750	3.44	.66	3 1/2	MK 2576	5/8-11 x 3 1/4	241	11.0
		1150-56-56	-----	-----	-----	-----	-----	-----	5/8-11		-----			
4 ^④	4	1149-64-64	5.50	6.50	2.50	5.125	3.062	3.94	.66	4	MK 2545	5/8-11 x 3 1/2	245	14.5
		1150-64-64	-----	-----	-----	-----	-----	-----	5/8-11		-----			

MATERIAL:
Low Carbon Steel [®]

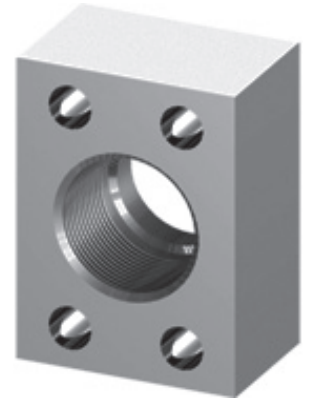
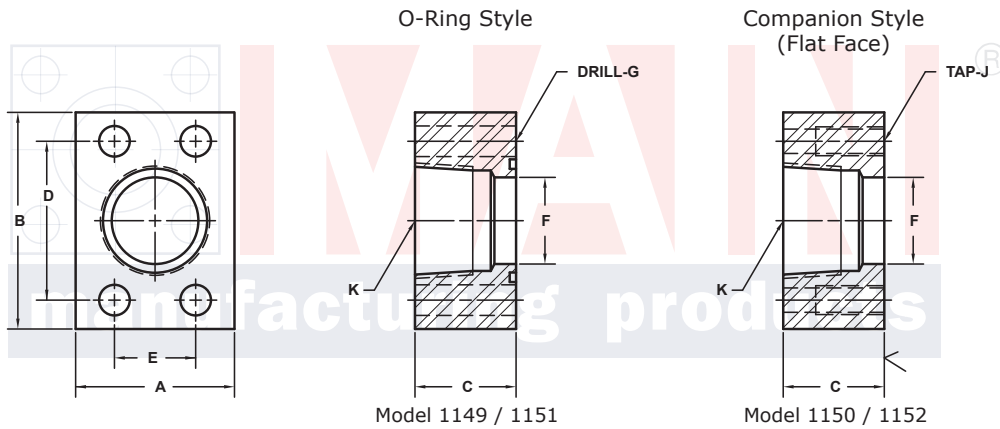

3181 TRI-PARK DR. GRAND BLANC, MI 48439 800-521-7918 810-953-1380 FAX 810-953-1385 INFO@MAINMFG.COM

SAE BOLT PATTERN										62 SERIES				
FLANGE SIZE	PIPE SIZE	PART NUMBER	A	B	C	D	E	F	G J	K NPTF	MOUNTING KIT®			WT
											PART NO.	SCREW SIZE	O-RING	
1 1/2	1 1/4	1151-24-20	3.25	4.50	1.75	3.125	1.437	1.50	.66	1 1/4	MK 527	5/8-11 x 2 3/4	225	5.7
		1152-24-20	-----	-----	-----	-----	-----	-----	5/8-11		-----			
1 1/2	1 1/2	1151-24-24	3.25	4.50	1.75	3.125	1.437	1.50	.66	1 1/2	MK 527	5/8-11 x 2 3/4	225	5.6
		1152-24-24	-----	-----	-----	-----	-----	-----	5/8-11		-----			
1 1/2	2	-----	4.00	4.50	4.00	3.125	1.437	1.50	---	2	-----	-----	---	17.0
		1152-24-32	-----	-----	-----	-----	-----	-----	5/8-11		-----			
2	1 1/2	1151-32-24	4.00	5.25	1.75	3.812	1.750	1.74	.78	1 1/2	MK 516	3/4-10 x 3	228	8.4
		1152-32-24	-----	-----	-----	-----	-----	-----	3/4-10		-----			
2	2	1151-32-32	4.00	5.25	1.75	3.812	1.750	1.94	.78	2	MK 516	3/4-10 x 3	228	7.8
		1152-32-32	-----	-----	-----	-----	-----	-----	3/4-10		-----			
2 1/2	2	1151-40-32	5.00	6.88	2.00	4.875	2.312	2.12	.94	2	MK 517	7/8-9 x 3 1/2	232	15.4
		1152-40-32	-----	-----	-----	-----	-----	-----	7/8-9		-----			
2 1/2	2 1/2	1151-40-40	5.00	6.88	2.00	4.875	2.312	2.44	.94	2 1/2	MK 517	7/8-9 x 3 1/2	232	15.1
		1152-40-40	-----	-----	-----	-----	-----	-----	7/8-9		-----			
3	3	1151-48-48	6.00	8.50	2.50	6.000	2.812	2.94	1.19	3	MK 718	1 1/8-7 x 4 1/2	237	27.5
		1152-48-48	-----	-----	-----	-----	-----	-----	1 1/8-7		-----			

① Order Separately

② 2500 PSI Max

③ 2000 PSI Max

④ 500 PSI Max

⑤ May Contain Lead